

en

Assembly and Operating Instructions Roller Shutter Drives with integrated radio receiver

Important information for:

- Fitters
- Electricians
- Users

Please forward accordingly!

These instructions must be kept for future reference.



Assembly and Operating Instructions

Table of Contents

General	2
Warranty.....	3
Safety Information.....	3
Intended Use	5
Mounting and installation instructions	5
Programming the switching times	13
Deleting the switching times	13
Technical Data	14
What should you do, if...?.....	15
Brief instructions commissioning PRF+	16

General

The roller shutter drives P5/16PRF+ to P9/16PRF+ are high quality products with a wide range of interesting features:

- **Radio-controlled individual, multi-point, group and central control**
- **No wiring required to the switch or to a relay control**
- **Drive and transmitters may be combined as you wish**
- **Installation possible without stoppers (lower limit to upper limit)**
- **Intermediate position setting**
- **Ventilation position setting**
- **Flexible radio-controlled group control, which can be changed at any time without complex installation**
- **Timer function with “Synchronised Sequence” and “Power Failure Correction”**
- **“Synchronised Sequence” function gives the optical impression of an occupied house**
- **Automatic detection of upper limit via intelligent electronic system**
- **Automatic detection of lower limit in connection with the anti-lifting lock system (axle shaft safety catches)**
 - **Secure anti-lifting lock system**
 - **Slight pressure applied to the shutters prevents them from being raised or forced open**
- **The limits do not have to be re-set: the shutter is realigned automatically if there are any changes in shutter length due to the use of stoppers at the upper limit**
- **Emergency stop control in accordance with the European Union Machinery Directive (anti-restart device)**
- **Torque control prevents the shutter from being damaged in the event of the shutter system being frozen or blocked**
- **Optimum closing torque adjustment**
- **Considerably less strain on the shutter and the stoppers even in systems with insulating plaster**
- **Longer service life thanks to smooth system and drive operation**

Always observe these assembly and operating instructions when installing and setting the device.

Warranty

Structural modifications and incorrect installation which are not in accordance with these and our other instructions can result in serious injuries, e.g. crushing of limbs. Therefore, structural modifications should only be carried out with our prior approval and in accordance with our instructions, particularly the information contained in these Assembly and Operating Instructions.

Any further processing of the products which does not comply with their intended use is not permitted.

The end product manufacturer and fitter have to ensure that all the current statutory, official regulations and, in particular, EMC regulations are adhered to during utilisation of our products, especially with regard to end product assembly, installation and customer advice.

Safety Information

The following safety instructions and warnings are intended to avert hazards and to prevent damage to property and personal injuries. **Please retain for future reference.**



Caution

Denotes a potentially hazardous situation. If this is not avoided, injuries may result.



Attention

Denotes a potentially hazardous situation. If this is not avoided, the product or something in its vicinity may be damaged.



Note

Denotes user tips and other useful information.



Important safety instructions for the user

Caution! Failure to observe these instructions can lead to serious injuries.

- **All operational work including maintenance and cleaning, on electrical installations as well as other parts of the construction must always be performed by authorised specialists, especially by qualified electricians.**
- **Do not allow children to play with control units.**
- **Systems have to be regularly checked by authorised specialists for wear and damages.**
- **Always put damaged systems out of operation immediately until they are repaired by an authorised specialist.**
- **Do not operate equipment if people or objects are within the danger zone.**
- **Observe the danger zone of the equipment during operation.**
- **Bring the equipment to a stop and disconnect the mains power supply when maintenance and cleaning jobs are performed either on the system itself or in the immediate vicinity of it.**
- **Ensure that there is an adequate distance (at least 40 cm) between moving parts and adjacent objects.**
- **Crushing and shearing points must be avoided or protected.**



Assembly and Operating Instructions



Important safety instructions for installation and commissioning

Caution! Failure to observe these instructions can lead to serious injuries.

- **Observe the safety instructions in EN 60335-2-97. Please note that this list of safety instructions is not exhaustive, since it would be impossible for the standard to include all sources of danger. For example, the design of the operated product, the way the drive works in the situation it is installed in or even the way the end product is mounted in the end user's place of use cannot be taken into consideration by the drive manufacturer.**
If any questions or uncertainties regarding the safety instructions contained in the standard arise, please contact the manufacturer of the part or end product in question.
- **All work, including maintenance and cleaning, on electrical installations as well as other system parts must always be performed by authorised specialists, in particular qualified electricians.**
- **When electrical or electronic equipment and units are operated, certain components, e.g., the power supply unit, are live. Physical injuries or damage to property can result in the event of unauthorised interventions or failure to heed warnings.**
- **All applicable standards and regulations for electrical installation must be complied with.**
- **Only use spare parts, tools and accessory devices which have been approved by the drive manufacturer.**
- **Unapproved third-party products or modifications to the system and its accessories represent a risk to your safety and the safety of others. This means that the use of unapproved third-party products, or modifications which have not been agreed with or approved by us, are prohibited. We do not accept liability for damages or injury arising from such actions.**
- **Before installation, shut down all lines and control devices that are not essential for operation.**
- **Position control devices within sight of the driven product at a height of over 1.5 m.**
- **Permanently mounted control devices must be positioned where they can be seen.**
- **Ensure that there is adequate clearance between moving parts and adjacent objects.**
- **Rated torque and duty cycle must be suitable for the requirements of the driven product.**
- **Technical data – rated torque and service life can be found on the type plate of the tubular drive.**
- **Moving parts of drives must be installed at a height of over 2.5 m above floor level or any other surface from which access to the drive is gained.**
- **Crushing or shearing points must be avoided or protected.**
- **Observe safety clearances in accordance with DIN EN 294.**
- **When installing the drive, all-pole disconnection from the mains with a contact gap of at least 3 mm per pole must be provided (EN 60335).**
- **If the drive mains connecting cable is damaged, it must be replaced with the same type of mains connecting cable (plug-in), which is available from the drive manufacturer.**
- **The drive must not be carried by the mains connecting cable.**
- **Drives with a H05VV-F connecting cable may only be used indoors.**
- **To connect the drive to the driven part, solely mechanical accessory components from the current Becker product catalogue may be used.**

Intended Use

All P5/16PRF+ to P9/16PRF+ tubular drives are intended solely for the operation of roller shutters. The tubular drive is fitted with springs which support both the shutter suspension and mechanical anti-lifting devices (e.g. Zurfluh-Feller, Simu, GAH Alberts or Deprat). These are detected automatically.

Other applications, utilisation and modifications are not permitted in order to protect the safety of the users and others, since these actions can impair the system's safety, resulting in personal injuries and property damage. Becker-Antriebe shall not accept liability for damages arising from such actions. Always observe the information in these instructions when operating or repairing the system. Becker-Antriebe shall not accept liability for damages resulting from incorrect usage.



Attention

Anti-lifting devices may only be used if sufficiently rigid roller shutter laths are used. When closed, the shutters must not extend over the guide rails, as this may put too great a load on the joint between the top two slats, which could consequently be damaged.

Before reaching the lower end limit, the roller shutters must have made at least 1.5 revolutions. This is normally the case when the window height is five times the effective tube diameter.

Example:

60-series octagonal tube with anti-lifting device from Zurfluh-Feller:

Effective tube diameter: 9 cm -> min. window height > 45 cm

Mounting and installation instructions

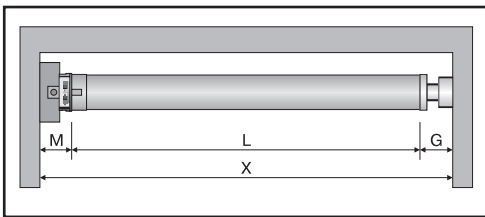
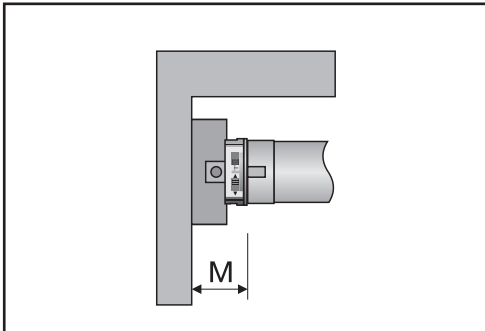

Mounting the roller shutter drive



Attention

Drives from Becker Antriebe are to be mounted and operated solely with mechanical accessory components shown in the current Becker product catalogue.

Prior to mounting, the fitter must ensure that the masonry and the shutter box are sufficiently robust (drive torque plus weight of the shutters).



Caution

These drives may not be operated with conventional switching elements (switches, timers or similar).

If the roller shutters are to be operated in the opposite direction to the upper stopper, the shutters must be stopped from being wound up into the shutter box by stoppers or by a right-angled end slat. We recommend fitting covered stoppers into the guide rails prior to mounting.

1. The lateral spatial requirements (M) for the box end, the counter bearing and the motor bearing must be determined in order to calculate the required length of the roller tube. The length (L) of the roller tube is equal to the clear dimensions of the roller shutter box (X) minus the total length of the wall bracket, box end (M) and counter bearing (G): $L = X - (G + M)$.

Measure the distance from the wall bracket and connecting head as this may vary depending on the drive and bearings used.

2. Secure the wall bracket and the counter bearing.



Attention

If anti-lifting devices are being used, closed bearings must be used. When the shutters are closed, the tubular drive pushes the shutters downwards to prevent them from being raised or forced open. To prevent the shutters from being damaged the entire shutter must run in guide rails.



Assembly and Operating Instructions

Drive adapter safety catch

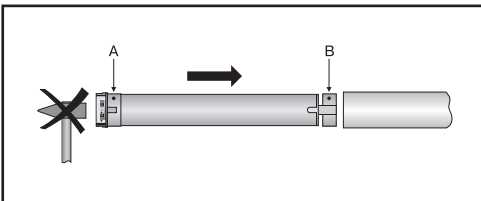
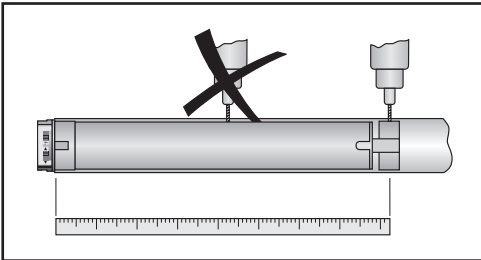
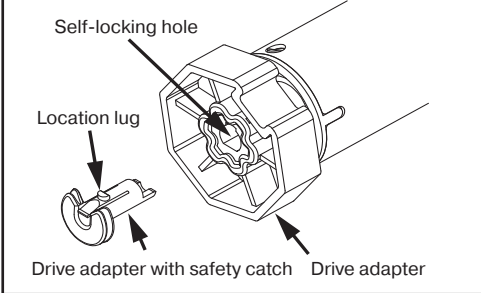

To install the drive, the following instructions must be followed carefully:

- **Mounting the drive adapter with safety catch:**

The insert direction for the drive adapter is determined by the drive adapter type (shape). When inserting the drive adapter with safety catch ensure that the catch engages with the location lug. You will hear a clicking sound when the drive adapter has engaged properly. Pull lightly on the drive adapter to ensure that it has been fitted securely.

3. The drive adapter of the tubular drive is connected to the roller tube as follows:

Size of drive [mm]	Roller shutter tubes-Ø [mm]	Torque max. [Nm]	Fastening screws for drivers (4 x)
Ø 35	40 mm plastic drive adapter	13	flat-headed sheet-metal screw ST 4.8 x 10 DIN 7982

The drive manufacturer also recommends screwing the opposite end bracket to the barrel.



Attention

When drilling the roller tube do not drill in the area around the tubular drive! The tubular drive must be inserted carefully into the tube. It should not be hammered or simply dropped into the tube! The shutters can be secured using springs or anti-lifting devices only.

- **Profile tubes:**

Attach a suitable limit ring adapter (A) and drive adapter (B) to the tubular drive. After having done so, slide the drive into the tube so that it engages positively. When doing so, ensure that the limit ring adapter and drive adapter fit securely into the tube.

For some drive adapters, the slot width tolerances of different roller tubes can be compensated by turning the drive adapter into another slot recess. These slot recesses have different dimensions and allow you to mount your drive accurately.

- **Round tubes:**

Release the tube at the motor end to allow the cam of the limit ring adapter to be slid into the tube. There must be no clearance between the cam of the limit ring adapter and the tube. For limit ring adapters without locating cams the roller tube must be connected to the limit ring adapter using a 4.8 x 10 mm tapping screw.

4. Insert the tube into the bearing and secure the motor end in the drive bearing.

5. After the transmitter programming, position the roller tube such that the roller shutters can be secured with springs. Alternatively, install the anti-lifting lock in accordance with the manufacturer's stipulations.



Note

When using springs we recommend that at least 3 are used; For longer roller tubes 3 springs are to be used per meter of roller tube.

Install motor connecting cable to the tubular drive in ascending direction and secure. The motor cable and the antenna must be well clear of the winding space. Sharp edges must be covered.

Acknowledgement

The roller shutter drive acknowledges every programme, setting or deletion process with a "clack" or "clack-clack" sound.

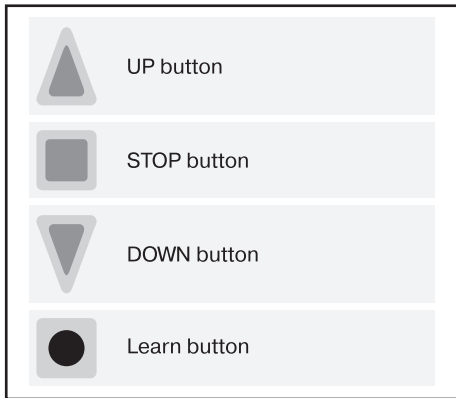

Action

Response

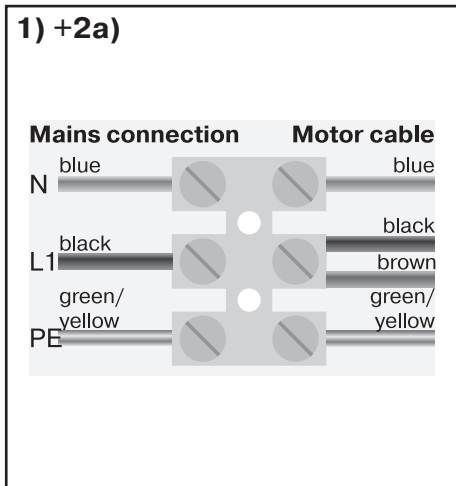

1) Connecting the tubular drive

Connect the tubular drive to the power supply and open the battery compartment of the hand-held transmitter.

2) Activating tubular drive learn mode

2a) Activating the tubular drive learn mode by switching on the power supply

Switch on the power supply.

The tubular drive goes into learn mode for 3 minutes.



Note

If several tubular drives are to be connected in parallel, one of the tubular drives can be deactivated from the learn mode by sliding the radio switch into the outer position after having switched on the power supply.

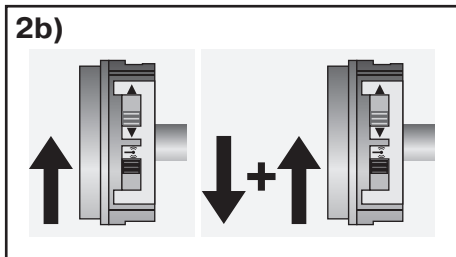

2b) Activating the tubular drive learn mode with the radio switch

Slide the radio switch into the inner position. If the switch is already in this position, move the button into the outer position and back to the inner position again.

The tubular drive goes into learn mode for 3 minutes.

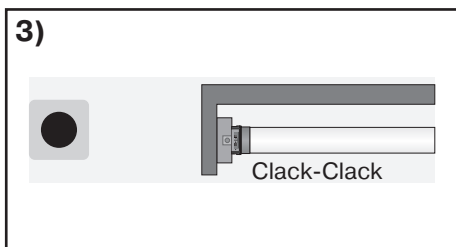

3) Learning the master transmitter

When the drive is in learn mode, press the learn button and hold for 3 seconds.

The tubular drive makes a "clack-clack" sound to confirm.

The learn process is complete.



Note

If a transmitter had already been programmed in the receiver, press and hold the learn button for 10 seconds.

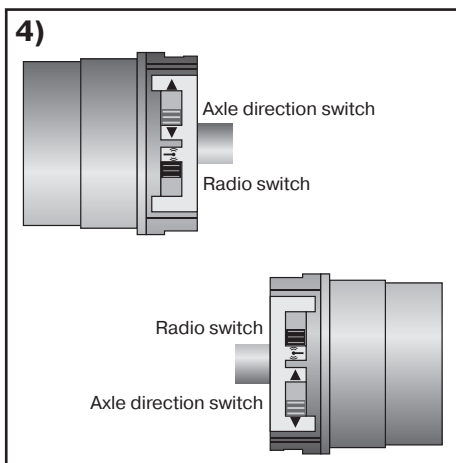

4) Checking the axle direction

Press the UP or DOWN button.

If the shutter moves in the desired direction => the axle direction is OK.

If the shutter moves in the wrong direction, the axle direction has to be changed. This is done as follows:

Slide the axle direction switch into the opposite position.

The axle direction has been altered. Re-check the axle direction.

Assembly and Operating Instructions

5) Setting the end limits



Note

The end limits can only be set via the master transmitter. The axle direction setting must be correct. When the end limits are being set, the tubular drive remains in lock-in mode. The lower end limit must always be programmed first. When setting the upper end limit, it is important to ensure that the shutter is securely in the guide rails.

There are 4 possible ways to set the end limits:

- a) Lower position to upper position without stopper
- b) Lower position to upper stopper
- c) Anti-lifting device at the lower limit to upper position without stopper
- d) Anti-lifting device at the lower limit to upper stopper

Action	Response
--------	----------

5a)

to 5a) Lower position to upper position without stopper



Note

For this end limit setting there is no automatic shutter curtain adjustment.

Adjust the shutter into the desired lower limit position.

First press and hold the learn button. Within 3 seconds also press the DOWN button and hold both buttons.

The tubular drive makes a “clack” sound to confirm.

Then adjust the shutter into the desired upper limit position.

First press and hold the learn button. Within 3 seconds also press the UP button and hold both buttons.

The tubular drive makes a “clack” sound to confirm. The end limits have been set.

5b)

to 5b) Lower position to upper stopper

Adjust the shutter into the desired lower limit position.

First press and hold the learn button. Within 3 seconds also press the DOWN button and hold both buttons.

The tubular drive makes a “clack” sound to confirm.

Then move the shutter up towards the permanent upper stopper.

The tubular drive switches off automatically. The end limits have been set.

5c)

to 5c) Anti-lifting device at the lower limit to upper position without stopper

Adjust the shutter downwards until they reach the lower limit position.

The tubular drive switches off automatically.

Then adjust the shutter into the desired upper limit position

First press and hold the learn button. Within 3 seconds also press the UP button and hold both buttons.

The tubular drive makes a “clack” sound to confirm. The end limits have been set.

Action

Response

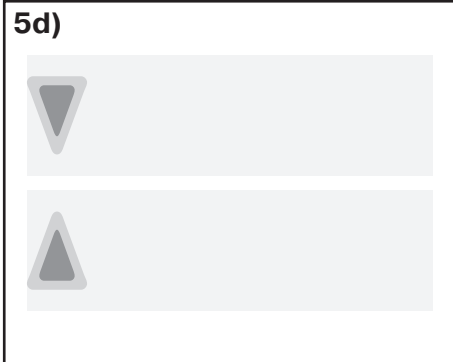

to 5d) Anti-lifting device at the lower limit to upper stopper

Adjust the shutters until they are in the lower limit position.

The tubular drive switches off automatically.

Then adjust the shutters up towards the permanent upper stopper.

The tubular drive switches off automatically.
The end limits have been set.

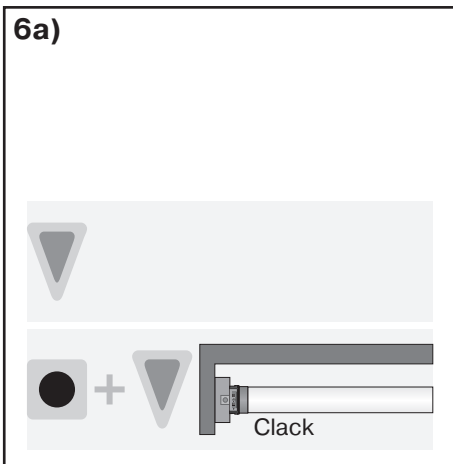

6) Changing the limit position settings

Note
The limit position settings can only be changed via the master transmitter.

6a) Decreasing the shutter travel distance (the desired limit position is within the existing travel distance)

Adjust the shutters into the new desired limit position.

First press and hold the learn button. Within 3 seconds also press the DOWN button for the lower limit or the UP button for the upper limit and hold both buttons.

The tubular drive makes a “clack” sound to confirm.
The new limit position has been stored.

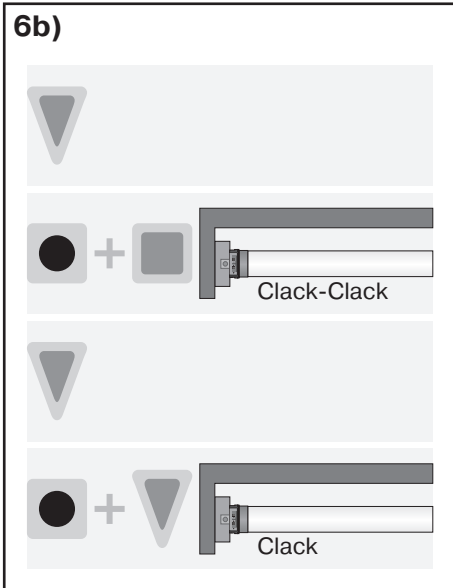

6b) Increasing the shutter travel distance (the desired limit position is outwith the existing travel distance)

Adjust the shutters to the limit position which you wish to extend. First press and hold the learn button.

Within 3 seconds also press the STOP button and hold both buttons pressed for 10 seconds.

The tubular drive makes a “clack-clack” sound to confirm.
The end limit has been deleted.

Now adjust the shutters into the new desired limit position.

First press and hold the learn button. Within 3 seconds also press the DOWN button for the lower limit or the UP button for the upper limit position and hold both buttons.

The tubular drive makes a “clack” sound to confirm.
The new end limit has been stored.

The final limit position becomes fixed, after the tubular drive has turned off automatically, in the desired position, three times.

Assembly and Operating Instructions

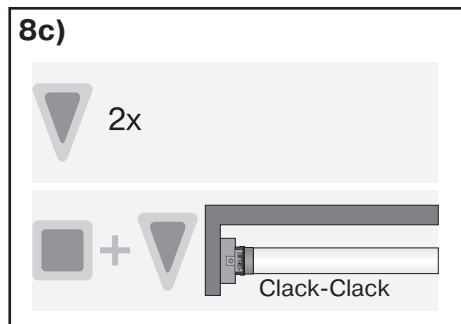
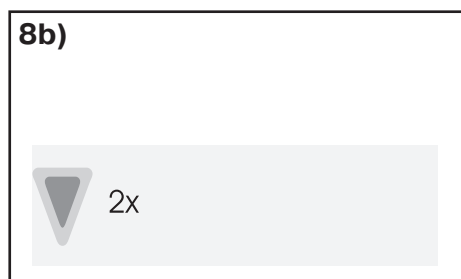
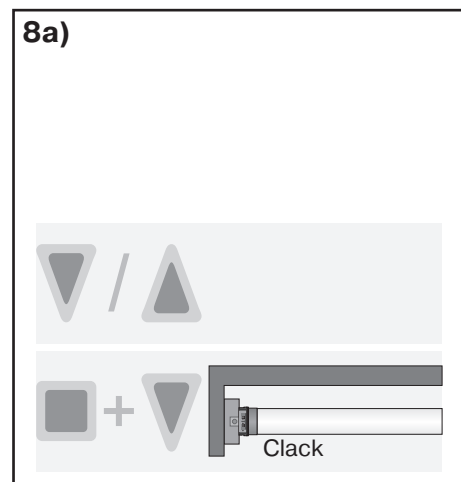
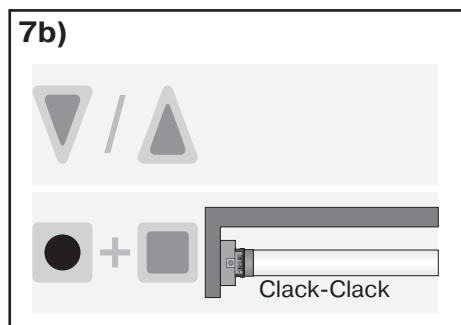
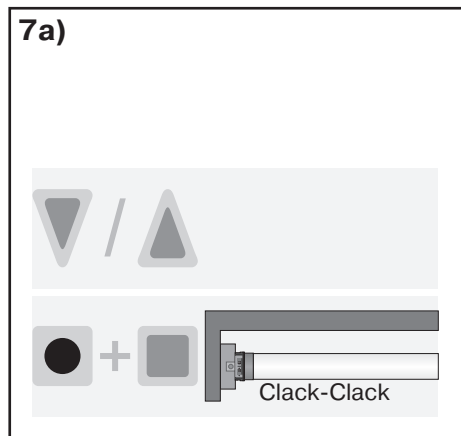

Action

Response

7) Deleting end limits

Note
The end limit settings can only be deleted via the master transmitter.

7a) Deleting the end limits individually

Adjust the shutter into the end limit position to be deleted.

First press and hold the learn button. Within 3 seconds also press the STOP button and keep both buttons pressed for 10 seconds.

The tubular drive makes a “clack-clack” sound to confirm.
The end limit has been deleted.

7b) Deleting both end limits

Adjust the shutter curtain into any position between the two end limits.

First press and hold the learn button. Within 3 seconds also press the STOP button and keep both buttons pressed for 10 seconds.

The tubular drive makes a “clack-clack” sound to confirm.
Both end limits have been deleted.

8) Intermediate position

Note
The intermediate position can be set at any given position and lies between the upper and lower end limits. The intermediate position can only be set after the two end limits have been set.

8a) Setting the intermediate position

Adjust the shutter curtain into the desired intermediate position.

First press and hold the STOP button. Within 3 seconds also hold the DOWN button and keep both buttons pressed.

The tubular drive makes a “clack” sound to confirm.
The intermediate position has been stored.

8b) Moving the shutter into the intermediate position

Note
The shutter moves into the intermediate position from the upper end limit.

Press the DOWN button twice within one second.

The shutter curtain moves into the intermediate position.

8c) Deleting the intermediate position

Adjust the shutter into the intermediate position.

First press and hold the STOP button. Within 3 seconds also hold the DOWN button and keep both buttons pressed.

The tubular drive makes a “clack-clack” sound to confirm.
The intermediate position has been deleted.

Action

Response

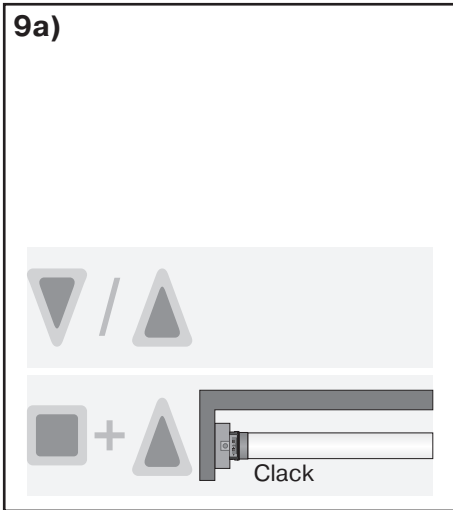

9) Ventilation position

Note
 This function is used to move your roller shutters from the lower end limit upwards in order to open the ventilation slats. The ventilation position can only be set after the two end limits have been set.

9a) Setting the ventilation position

Adjust the shutter into the desired ventilation position.

First press and hold the STOP button. Within 3 seconds also press the UP button and keep both buttons pressed.

The tubular drive makes a “clack” sound to confirm. The ventilation position has been stored.

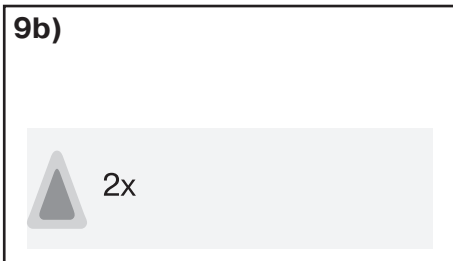

9b) Adjusting the shutters into the ventilation position

Note
 The shutters move into the ventilation position from the lower end limit.

Press the UP button twice within one second.

The shutter curtain moves into the ventilation position.

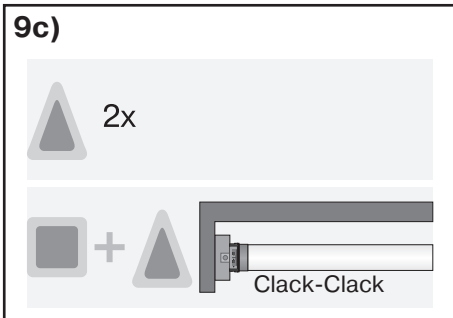

9c) Deleting the ventilation position

Adjust the shutter into the ventilation position.

First press and hold the STOP button. Within 3 seconds also press the UP button and keep both buttons pressed.

The tubular drive makes a “clack-clack” sound to confirm. The ventilation position has been deleted.

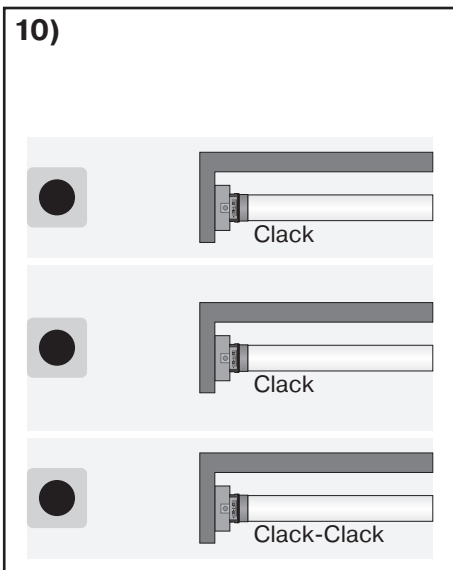

10) Learning additional transmitters

Note
 In addition to the master transmitter, up to 15 transmitters can be learnt into the tubular drive system.

Press the learn button of the master transmitter programmed in 3) for 3 seconds.

The tubular drive makes a “clack” sound to confirm.

Now press the learn button of a new transmitter which is unknown to the tubular drive for 3 seconds. In doing so, the tubular drive goes into the programme mode for a new transmitter for 3 minutes.

The tubular drive makes a “clack” sound to confirm.

Now press the learn button of the transmitter to be programmed for a further 3 seconds.

The tubular drive makes a “clack-clack” sound to confirm. The new transmitter has been programmed.

Assembly and Operating Instructions

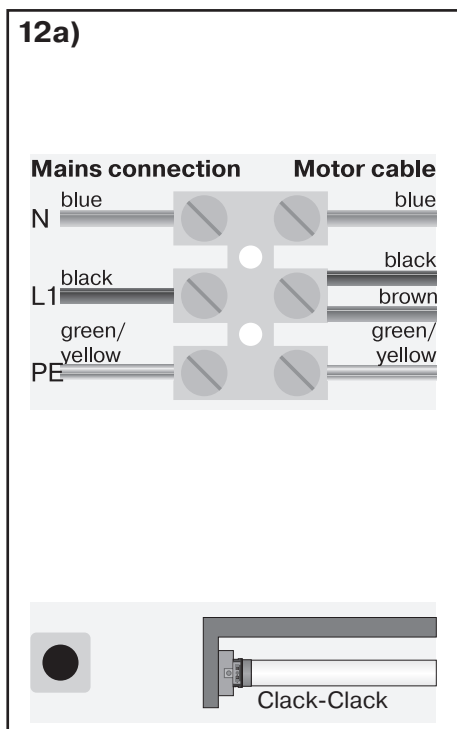
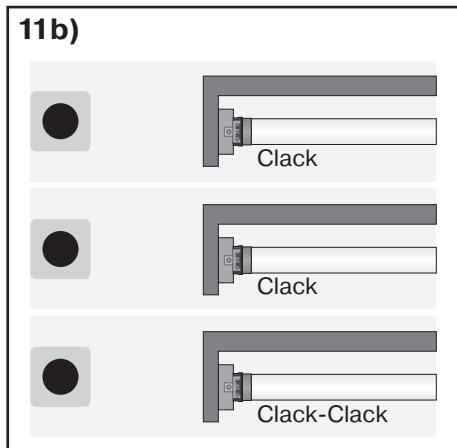
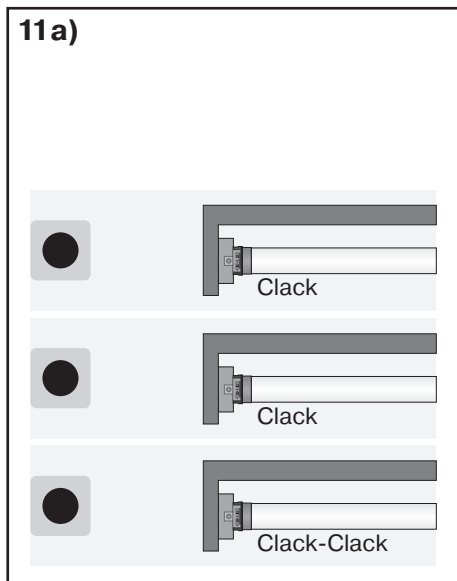

Action	Response
--------	----------

11) Deleting transmitters

11a) Deleting transmitters individually

Note
The master transmitter which was programmed in point 3) cannot be deleted. It can only be overwritten (see Point 12).

Press the learn button on the master transmitter for 3 seconds. The tubular drive makes a “clack” sound to confirm.

Now press the learn button of the transmitter to be deleted for 3 seconds. The tubular drive makes a “clack” sound to confirm.

Then press the learn button of the transmitter to be deleted for a further 10 seconds. The tubular drive makes a “clack-clack” sound to confirm. The transmitter has been deleted from the tubular drive.

11b) Deleting all transmitters (except master transmitter)

Press the learn button on the master transmitter for 3 seconds. The tubular drive makes a “clack” sound to confirm.

Now press the learn button on the master transmitter for a further 3 seconds. The tubular drive makes a “clack” sound to confirm.

Now press the learn button on the master transmitter for a further 10 seconds. The tubular drive makes a “clack-clack” sound to confirm. All transmitters (except the master transmitter) have been deleted from the receiver.

12) Overwriting the master

There are 2 ways to overwrite the master transmitter:

- Activate tubular drive programme mode by switching on the power supply
- Activate tubular drive programme mode using the radio switch

12a) Activating the tubular drive programme mode by switching on the power supply

Switch off the tubular drive’s power supply and switch back on after 5 seconds. The tubular drive goes into programme mode for 3 minutes.

Note
To ensure that the new master transmitter is programmed into the desired tubular drive only, all other tubular drives which are connected to the same power supply must be deactivated from the programme mode. To do so, after switching back on the power supply, execute a control or stop command using the transmitter for the given drives or adjust the radio switch from the inner to the outer position. If the radio switch is already in this position, slide the switch inwards and then back to the outer position.

Now press the learn button of the new master transmitter for 10 seconds. The tubular drive makes a “clack-clack” sound to confirm. The new master transmitter has been programmed and the old master transmitter has been deleted.

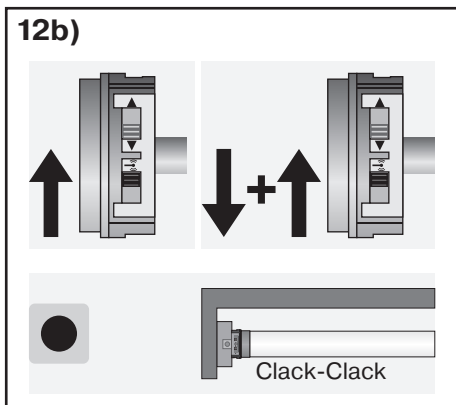

Action

Response

12b) Activating the tubular drive programme mode with the radio switch

Slide the radio switch into the inner position. If the radio switch is already in this position, slide the switch outwards and then back to the inner position again.

The tubular drive goes into programme mode for 3 minutes.

Now press the learn button of the new master transmitter for 10 seconds.

The tubular drive makes a “clack-clack” sound to confirm. The new master transmitter has been programmed and the old master transmitter has been deleted.

Programming the switching times

Note
This function is only available with the transmitters MemoControl MC441, MC411, MC441-II and MC411-II from the Becker Centronic range of control units.
When both or individual limit positions are deleted, this set function is deleted as well.

Every tubular drive can store switching times for one UP and one DOWN command. If the sliding switch is set to “Clock” this roller shutter command is repeated every 24 hours. The position of the manual/auto sliding switch is unimportant when programming the switching time. All previously stored switching times are deleted accordingly.

1. Adjust the roller shutters, if necessary, until they are in the limit position opposite to the desired running direction.
2. Wait until the time at which the automatic control command is to be executed.
3. At the preset time activate the desired direction key and hold down until the roller shutter system stops briefly after approximately 6 seconds and then moves onto the limit position.
4. Release direction key.

The tubular drive will automatically store the current time for this control command.

Deleting the switching times

Note
Both switching times are always deleted in this process.

In order to delete the times the UP and DOWN control commands are to be triggered, press the STOP button for 10 seconds. This is acknowledged by a double click of the tubular drive. The switching times have been deleted.

Assembly and Operating Instructions

Technical Data

Type	P5/16PRF+	P5/20PRF+	P9/16PRF+
Nominal torque (Nm)	5	5	9
Output speed (min ⁻¹)	16	20	16
Limit switch range	64 revolutions		
Mains voltage	230 V AC / 50 Hz		
Power consumption (W)	85	115	110
Nominal current consumption (A)	0,36	0,47	0,47
Operating mode	S2 4 Min.		
Protection class	IP 44		
Min. tube diameter (mm)	37		
Frequency	868,3 MHz		

What should you do, if...?

Malfunction	Cause	Solution
Tubular drive is not running.	<ol style="list-style-type: none"> 1. No transmitter has been programmed. 2. Transmitter is outwith the range of the tubular drive. 3. Transmitter has been operated outwith the range several times. 4. Batteries in the transmitter have been incorrectly inserted, not inserted at all or are empty. 5. Faulty electrical connection. 6. Thermal cut-out function in the tubular drive has been activated. 	<ol style="list-style-type: none"> 1. Programme new transmitter. 2. Move transmitter into the range of the tubular drive. 3. Activate the control or stop button on the transmitter at least 5 times. 4. Insert batteries properly or replace batteries. 5. Check electrical connection. 6. Wait 5-10 minutes.
You are unable to change the axle direction.	End limits are stored in the tubular drive.	Start up the tubular drive via a start command and deactivate with a stop command. Then delete the end limit settings using the programming and stop buttons.
The axle direction is incorrect after deleting the end limits.	The axle direction switch is in the wrong position.	Slide the axle direction switch to the opposite position.
Tubular drive has stopped at random and won't run in the given direction.	<ol style="list-style-type: none"> 1. Tubular drive has detected an assumed load. 2. Tubular drive is overloaded. 	<ol style="list-style-type: none"> 1. Run the drive briefly in the opposite direction, then activate the desired direction again. 2. Use a tubular drive with a greater torque.
Rohrantrieb nimmt keine Schaltzeiten an.	Eingelernter Sender hat keinen Hand/Auto Schiebeschalter.	Sender mit Hand/Auto-Schiebeschalter verwenden.
Switching times cannot be stored in the tubular drive.	<ol style="list-style-type: none"> 1. The manual/auto sliding switch is set to ☯. 2. Several sliding switch transmitters are programmed in the tubular drive. One manual/auto sliding switch is set to ☯. 	<ol style="list-style-type: none"> 1. Adjust the manual/auto sliding switch to ☺. 2. Adjust the sliding switch of one transmitter to ☺. If the sliding switch is already set to ☺, slide the switch briefly to ☯ and back to ☺ again.
The switching time settings keep changing.	Frequent 230V supply voltage interruption. Fluctuations in the 50 Hz power frequency.	
Tubular drive is not adjusting the shutters into the preset ventilation and intermediate positions.	The upper end limit has been set first.	The end limits have to be reset. Remember to set the lower limit first!
During programming travel the drive does not reach the limit stop which is to be programmed.	For safety reasons the drive reacts cautiously to unsmooth running during programming travel, thus preventing damages.	Briefly travel DOWN and subsequently UP until you reach the upper limit stop.

Assembly and Operating Instructions

Brief instructions commissioning PRF+



Caution

Always adhere to the information contained in the assembly and operating instructions during commissioning, operation and repair work. The manufacturer or supplier shall not accept liability for personal injuries, property damage or consequential damages resulting from non-adherence to the instructions.

1. Connection

Connect the wires to the power supply as displayed in the example below.

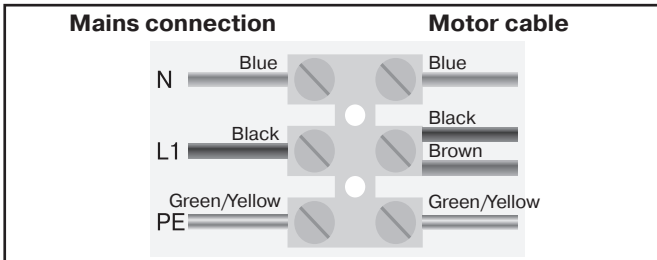

The brown wire and black wire are connected together at "L".

2. Learning the master transmitter

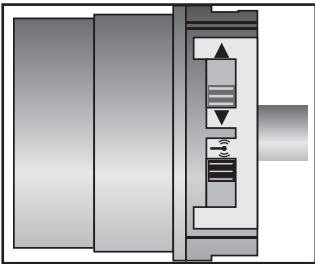

Slide the radio switch to position (P). (The tubular drive goes into learn mode for 3 minutes).

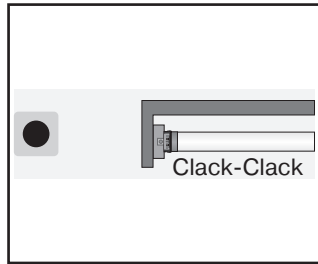

Press the learn button at the master transmitter until the tubular drive makes a "clack-clack" sound.

3. Checking / Correcting the axle direction

If the axle moves in the wrong direction, change the position of the axle direction switch on the tubular drive.

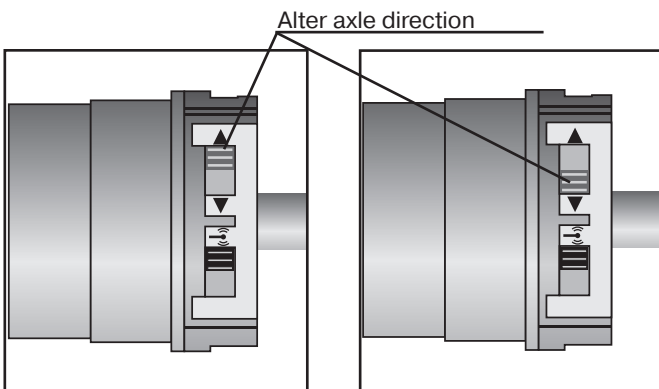

The axle direction can only be altered if end limits have not been set!

4. Setting the end limits

Lower position to upper position without stopper

Travel to the desired lower end limit position.

Subsequently press the learn button and the DOWN button until the tubular drive makes a "clack" sound.

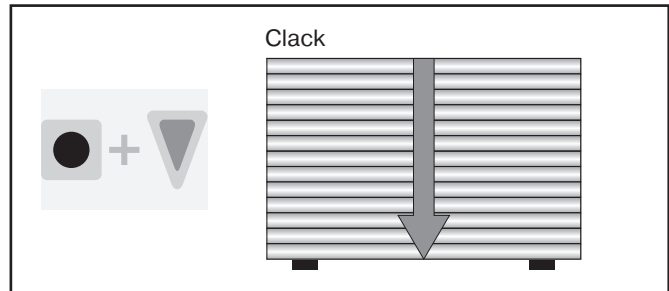

Travel to the desired upper end limit position.

Subsequently press the learn button and the UP button until the tubular drive makes a "clack" sound.

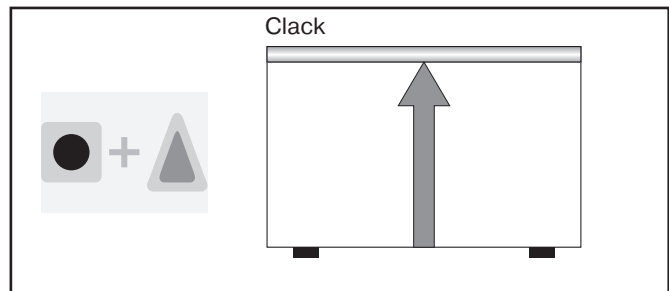

With permanent stoppers (stopper for the upper end limit or anti-lifting devices for the lower end limit), the tubular drive automatically stops during installation travel and automatically saves the end limit(s).

5. Deleting the end limit(s)

Press the learn button and the STOP button until the tubular drive makes a "clack-clack" sound.

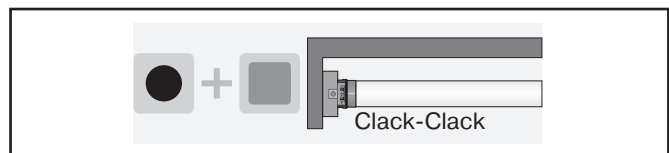

If the tubular drive is located between the end limits, both end limits are deleted. If the tubular drive is located at one of the two end limits, only the respective end limit is deleted.